

ASSEMBLY AND INSTALLATION INSTRUCTIONS

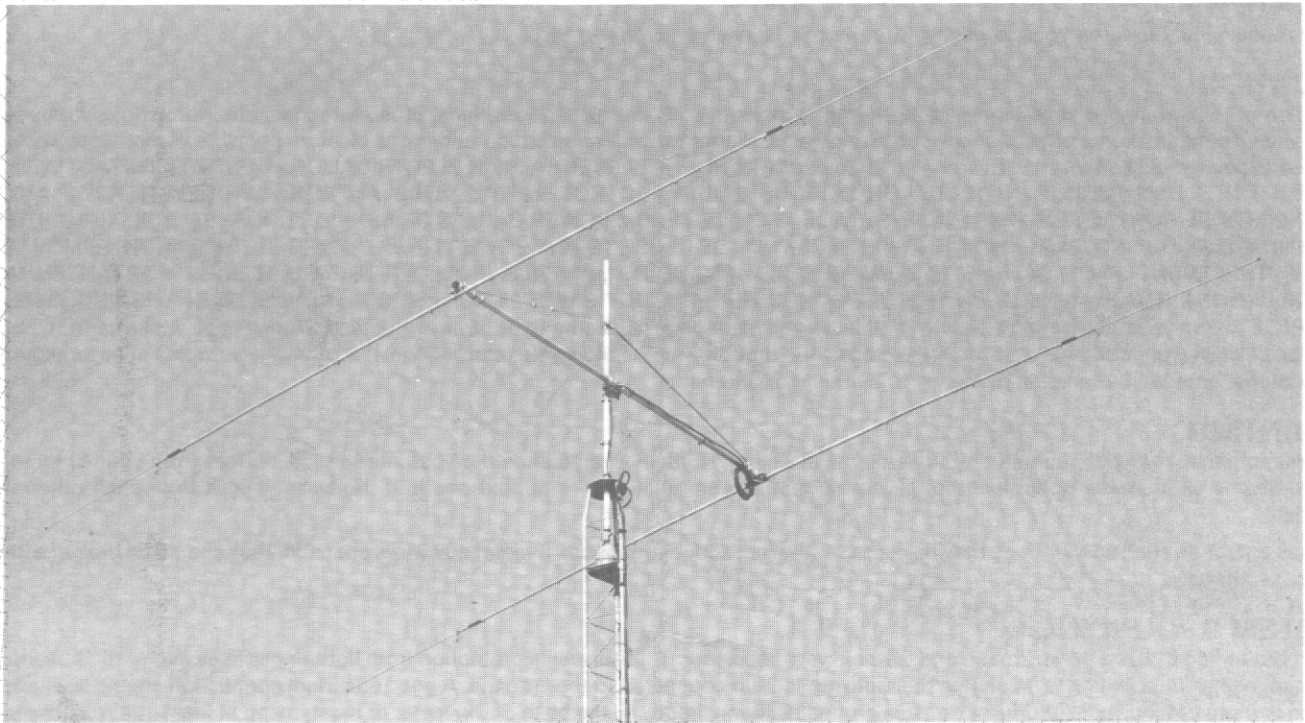

40-2CD
40 METER SKYWALKER



Your Cushcraft 40 meter beam is designed and manufactured to give top performance and trouble free service. The antenna will perform as specified if the instructions and suggestions are followed and care is used in assembly and installation. When checking the tubing received with your antenna package using the parts list, it is easiest to identify the various dimensions of tubing by separating them into groups of the same diameter and length.

MASTING

The mast mount bracket will accommodate up to a 2 1/8 in. OD (5.34 cm) mast.

ROTATOR

A good heavy duty antenna rotator will provide the best service and longest life.

LOCATION

Location of the antenna is very important. Surrounding objects such as trees, power lines, other antennas, etc. will seriously reduce efficiency. To minimize the effects of surrounding objects, mount the antenna as high and in the clear as possible. If metal guy wires are used, they should be broken with strain insulators. **WARNING: THE ANTENNA IS AN ELECTRICAL CONDUCTOR. CONTACT WITH POWER LINES CAN RESULT IN DEATH, OR SERIOUS INJURY. DO NOT INSTALL THIS ANTENNA WHERE THERE IS ANY POSSIBILITY OF CONTACT WITH OR HIGH VOLTAGE ARC-OVER FROM POWER CABLES OR SERVICE DROPS TO BUILDINGS. THE ANTENNA, SUPPORTING MAST AND/OR TOWER MUST NOT BE CLOSE TO ANY POWER LINES DURING INSTALLATION, REMOVAL OR IN THE EVENT PART OF THE SYSTEM SHOULD ACCIDENTALLY FALL. FOLLOW THE GUIDELINES FOR ANTENNA INSTALLATIONS RECOMMENDED BY THE U.S. CONSUMER PRODUCT SAFETY COMMISSION AND LISTED IN THE ENCLOSED PAMPHLET.** Plan your installation carefully. If you use volunteer helpers be sure that they are qualified to assist you. Make certain that everyone involved understands that you are the boss and that they must follow your instructions. If you have any doubts at all employ a professional antenna installation company to install your antenna.

MOUNTING

Several antennas may be mounted on the same mast. Short VHF/UHF Beams should be mounted at least 5 feet from your 40 meter beam. Beams with similar boom lengths to your 40 meter beam should be mounted one half the boom length from each other, if practical.

Vertical antennas such as the Ringo may be placed a few feet above your beam. If metal guy wires are used, they should be broken with strain insulators.

SYSTEM GROUNDING

Direct grounding of the antenna, mast, and tower is very important. This serves as protection from lightning-strikes and static buildup, and from high voltage which is present in the radio equipment connected to the antenna. A good electrical connection should be made to one or more ground rods (or other extensive ground system) directly at the base of the tower or mast, using at least 10AWG ground wire and non-corrosive hardware. For details and safety standards, consult the National Electrical Code. You should also use a coaxial lightning arrester like the Blitz Bug in your feedline.

BOOM ASSEMBLY

Assemble the boom using Figure 1. BC is placed in the end of one BB and secured with a H32 clamp. Place remaining BB over the exposed end of BC and secure with H32. Now clamp assembly to plate 76. Tighten the U bolts snugly but do not crush boom. Next slide BA into each end of BB 4 inches and tighten. Place end caps #99 on each end. Your boom is now assembled. Check to insure that it is the correct length.

ELEMENT ASSEMBLY

Lay out the element pieces using Figure 2. First assemble the driven element center insulator and the two 72 inch (182.9 cm) pieces attached to it. One end of EG has holes drilled through it. Identify and insert this end into INS. Put (#120) 2 inch (5.1 cm) machine screw through and attach hardware shown in Figure 2A. The RF choke consists of 12 turns of your feedline in a 6 to 8 inch (15 to 20 cm) diameter coil. This coil will prevent RF from radiating along the feedline. Use care to waterproof the feed as shown. Now progressing along the element slide in the next smaller diameter tube and install the proper clamp. Each insert is 4 inches (10.16 cm) except that EB is inserted 18" (45.7 cm) into EA. The exposed length of the outermost piece is shown in the chart. Next assemble the reflector in a like manner. The capacitive X-hats are identical in each case. Assemble and install them using Figure 2B.

Check to see that all fittings are tight and that all measurements are correct.

BOOM TO ELEMENT ASSEMBLY

Attach the boom to element mounting plate to the driven element insulator (INS). This plate 133-1M has the U-bolt holes farthest apart to accommodate the phenolic insulator. Now place the assembly on the boom and attach the other U-bolts and hardware. After determining that the elements are parallel tighten the U-bolts but use care not to crush the boom. See Figure 3.

BRACE ASSEMBLY

Assemble both braces using Figure 4. Be sure that the flattened ends are parallel. Place a brace clamp (126) over each of the 2 inch (5.08 cm) boom sections. Loosely attach the hardware through the clamp and brace. Attach the U-bolt (98), V-block (63) etc., at the intersection of the two braces. Align the U-bolt in the brace with the U-bolts in the boom to mast assembly. The distance between these two is usually determined by your installation (28 inches (71 cm) is a typical distance). If the distance is much larger the brace clamp (126) should be installed on the 2 1/8 in (5.39 cm) tubing. Now tighten the brace clamp securely.

FINAL CHECK

Now check your antennas dimensions using the overview drawing, Figure 5. Your antenna is now ready for installation on your support. Note: checking the VSWR near the ground will provide erroneous results. The antenna must be in its working position for a good VSWR test.

BOOM ASSEMBLY

✓

PART NUMBER	DESCRIPTION	SIZE	QUANTITY
BA	ALUM TUBING	2" × 56" (5.08 × 142.2 cm)	2
BB	ALUM TUBING	2 1/8" × 84" (5.40 × 213.36 cm)	2
BC	ALUM TUBING	2" × 18" (5.08 × 45.72 cm)	1
34	U-BOLT	2 1/2" (6.35 cm)	4
36	LOCK WASHER	3/8" (.95 cm)	8
37	NUT	3/8" (.95 cm)	8
35	V-BLOCK	3 1/2" (6.35 cm)	4
76	MOUNTING PLATE	6" × 7" (15.24 × 17.78 cm)	1
H32	WORM CLAMP	2 1/2" (6.35 cm)	4
99	BLACK PLASTIC CAPS	2" (5.1 cm)	2

●
●
●
✓
✓
✓
✓
●
✓
✓

FIGURE 1

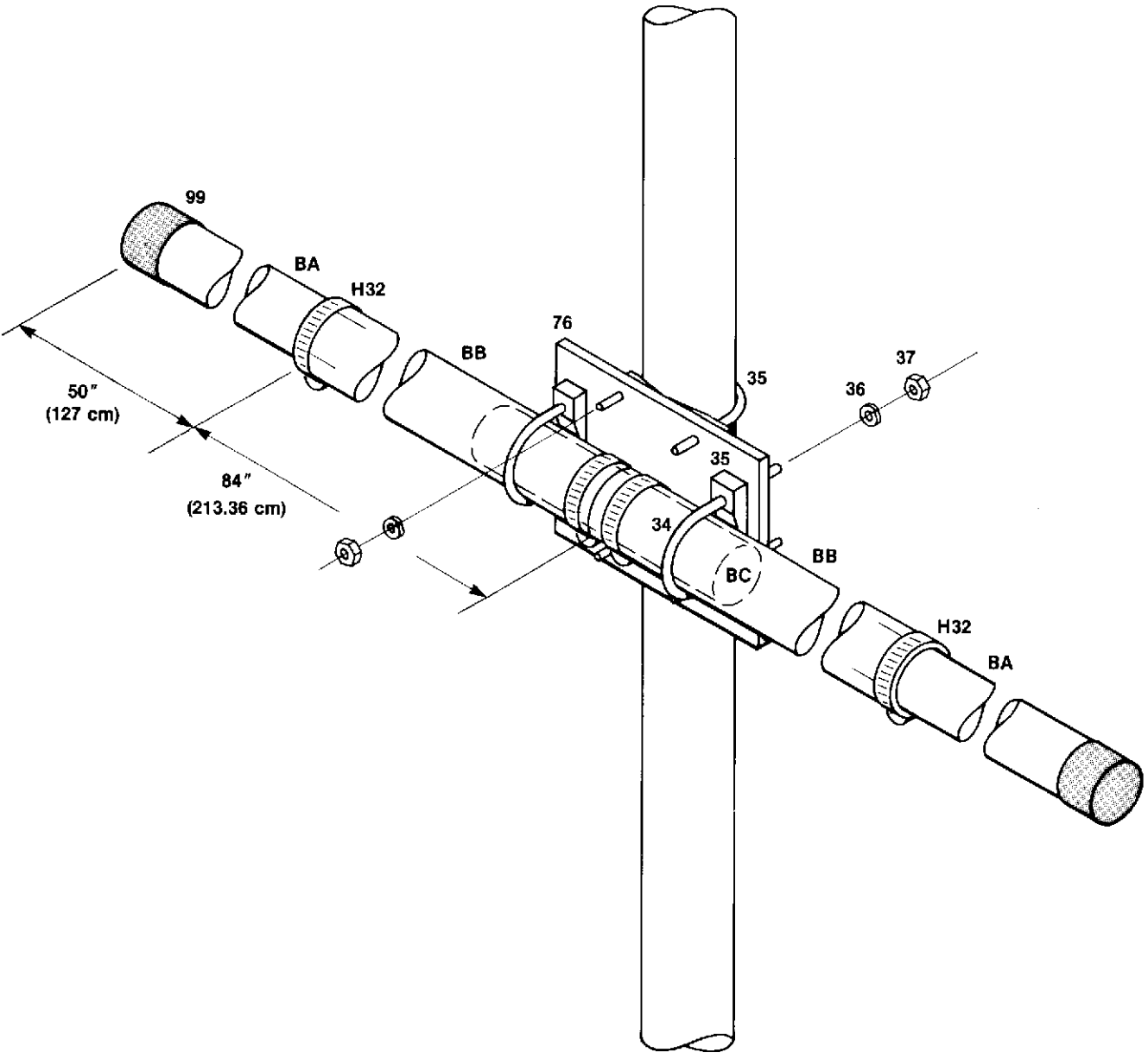

ELEMENT ASSEMBLY

PART NUMBER	DESCRIPTION	SIZE	QUANTITY
EA	ALUM TUBING	1 3/8" x 36" (3.5 x 91.4 cm)	1
EB	ALUM TUBING	1 1/4" x 72" (3.2 x 182.9 cm)	2
EG	ALUM TUBING	1 1/4" x 72" (3.2 x 182.9 cm)	2
EC	ALUM TUBING	1 1/8" x 48" (2.8 x 121.9 cm)	4
ED	ALUM TUBING	1" x 48" (2.54 x 121.9 cm)	4
EE	ALUM TUBING	1/2" x 83" (1.3 x 210.8 cm)	2
EF	ALUM TUBING	1/2" x 76" (1.3 x 193.1 cm)	2
LCA	LOADING COIL ASS'Y	1 5/8" x 23 1/2" (4.1 x 59.7 cm)	4
INS	INSULATOR	2" x 8" (5.1 x 20.3 cm)	1
XHR	ALUMINUM ROD	3/16" x 34 1/2" (.5 x 87.6 cm)	8
120	MACHINE SCREW	8-32 x 2" (5.1 cm)	2
10	LOCK WASHER	#8	20
11	NUT	#8	8
145	TERMINAL	#8	2
123	MACHINE SCREW	8-32 x 1 1/2" (3.8 cm)	4
25	FORMED ALUM BRACKET	7/8" (2.2 cm)	4
157	FORMED ALUM BRACKET	2" x 3/4" (5.1 x 1.9 cm)	4
S-8	WORM CLAMP	7/8" (2.2 cm)	4
S-10	WORM CLAMP	1 1/8" (2.9 cm)	12
S-20	WORM CLAMP	1 1/2" (3.8 cm)	6
500	WARNING LABEL		1
53	BLACK PLASTIC CAPS	1/2" (1.3 cm)	4
28	ALUMINUM HALF WASHER		4

FIGURE 2B

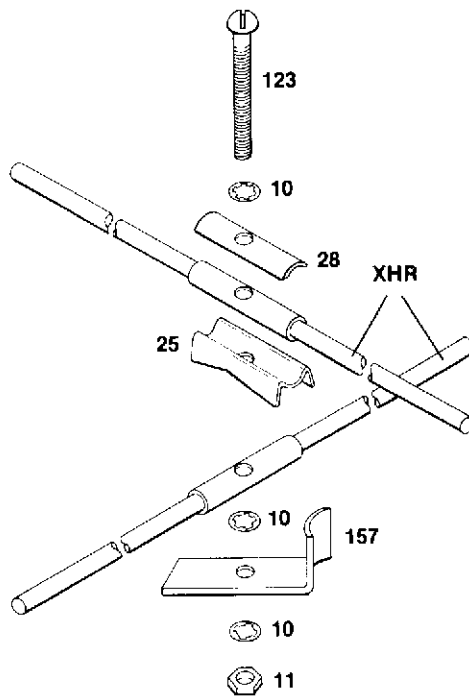

FIGURE 2

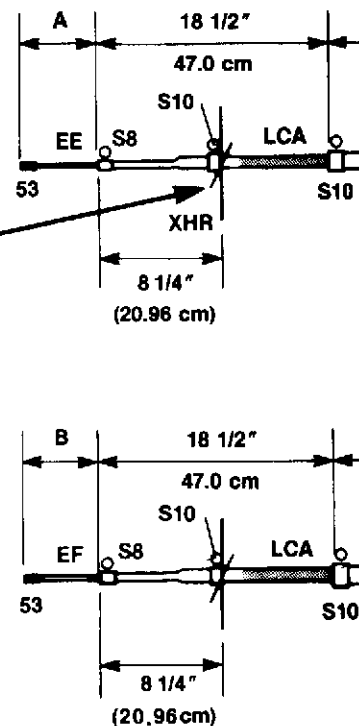
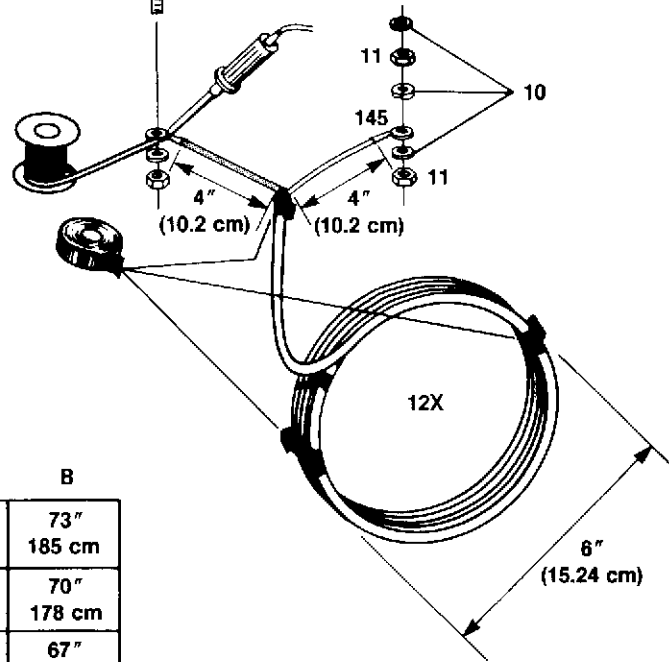
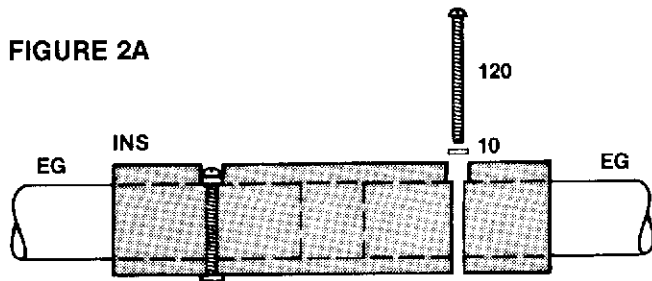
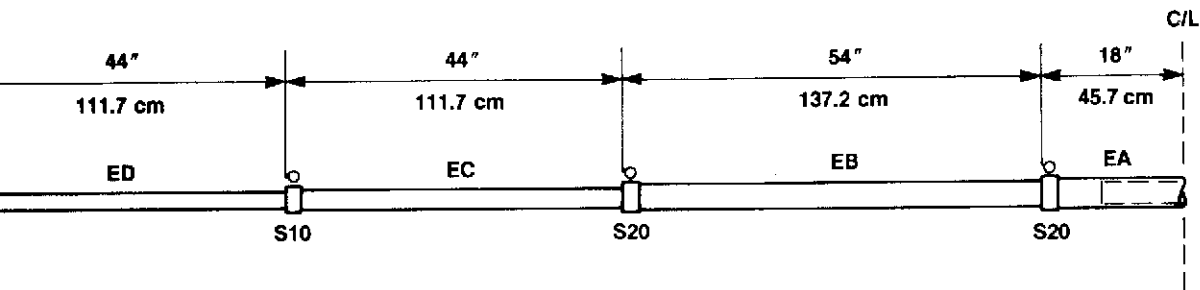

FIGURE 2A



	A	B
CW	80" 203 cm	73" 185 cm
MID	77" 196 cm	70" 178 cm
PHONE	74" 188 cm	67" 170 cm



REFLECTOR

BOTH SIDES OF
ELEMENTS ARE
IDENTICAL

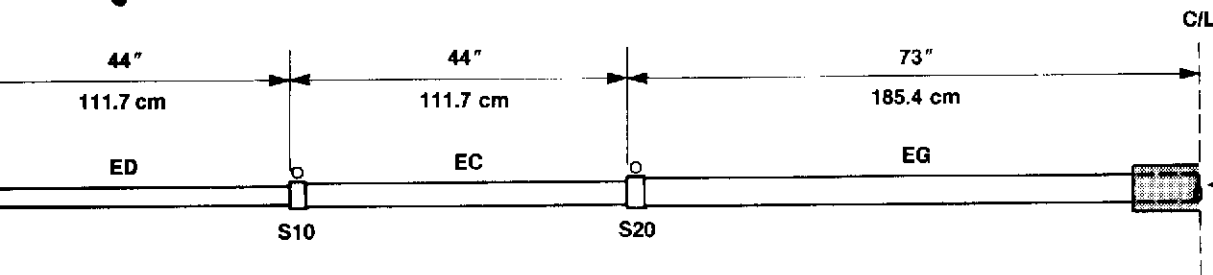

DRIVEN
ELEMENT

BOOM TO ELEMENT ASSEMBLY

PART NUMBER	DESCRIPTION	SIZE	QUANTITY
1	U-BOLT	2" (5.1 cm)	6
2	U-BOLT	1 5/8" (4.2 cm)	2
5	LOCKWASHER	5/16" (.8 cm)	16
6	NUTS	5/16" (.8 cm)	16
133-1M	PLATE	3 1/2" x 6" (8.9 x 17.6 cm)	1
133-2	PLATE	3 1/2" x 6" (8.9 x 17.6 cm)	1

FIGURE 3

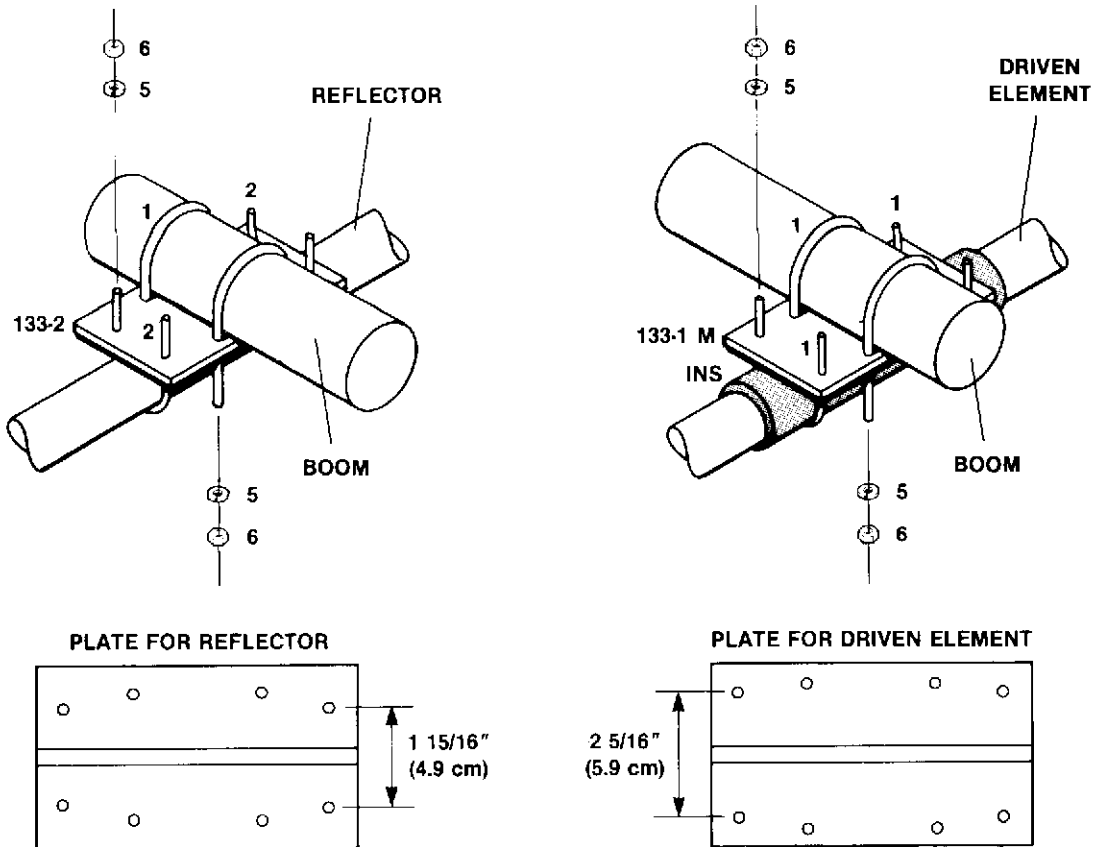

BRACE ASSEMBLY

PART NUMBER	DESCRIPTION	SIZE	QUANTITY
BG	ALUM TUBING	3/4" x 48" (1.9 x 121.9 cm)	4
BH	ALUM TUBING	7/8" x 12" (2.2 x 30.5 cm)	2
98	U-BOLT	2 1/8" x 3" (.4 x 7.6 cm)	1
S8	WORM CLAMP	7/8" (2.2 cm)	4
63	V-BLOCK	2 1/2" (6.4 cm)	1
42	HEX HEAD BOLT	5/16" x 1 1/2" (.8 x 3.8 cm)	2
5	LOCK WASHER	5/16" (.8 cm)	6
6	NUT	5/16" (.8 cm)	4
126	BRACE CLAMP	2" (5.1 cm)	2

FIGURE 4

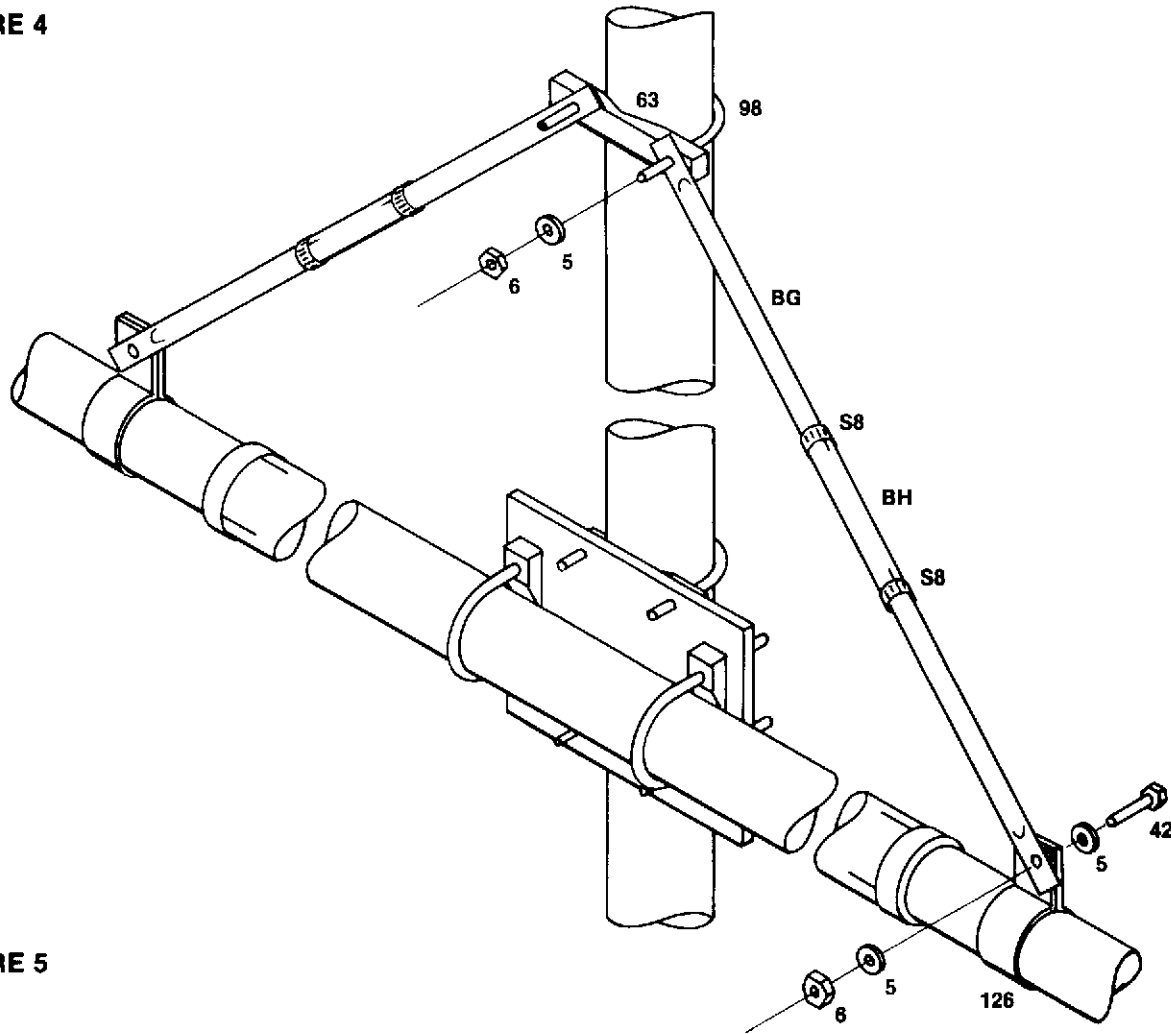
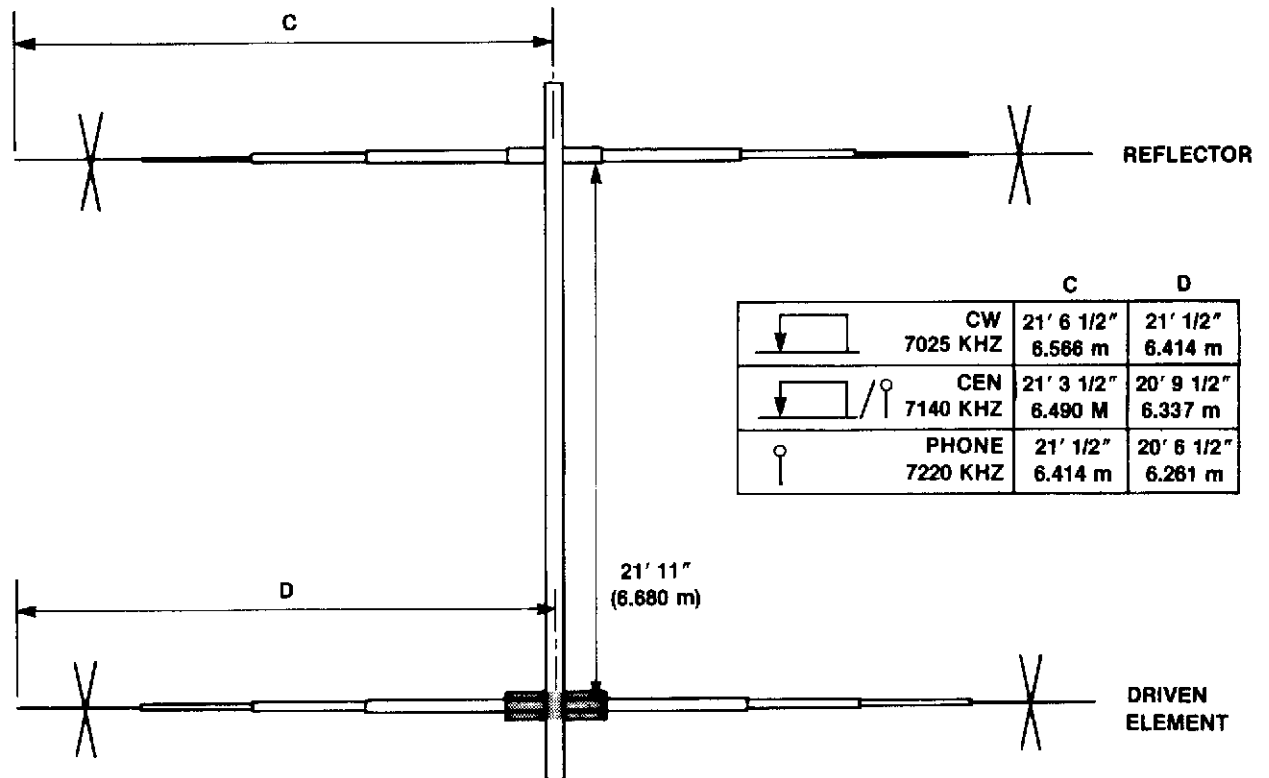

FIGURE 5



40 METER SKYWALKER SPECIFICATIONS

Forward Gain, dBd	5.5
Front to Back Ratio, dB	20
Boom Length, ft (m)	22.3 (6.8)
Longest Element, ft (m)	43 (13.1)
Turning Radius, ft (m)	23.93 (7.3)
3 dB Beamwidth, deg	75
Assembled Weight, Lb. (Kg)	44 (20)
Surface Area, Sq. ft (Sq. m)	6.38 (.59)
Frequency Coverage, MHz	7.0 - 7.3
Bandwidth, 2:1 VSWR	200 KHz
Wind Survival, mph (kph)	80 mph (125 kph)
Maximum Mast OD, in. (cm)	2.125 (5.34 cm)
Material	6063-T832 Seamless Tubing
Termination	Stainless Steel Terminals

SPECIFICATIONS SUBJECT TO CHANGE WITHOUT NOTICE.

LIMITED WARRANTY

CUSHCRAFT CORPORATION, P.O. BOX 4680, MANCHESTER, NEW HAMPSHIRE 03103, WARRANTS TO THE ORIGINAL CONSUMER PURCHASER FOR ONE YEAR FROM DATE OF PURCHASE THAT EACH CUSHCRAFT ANTENNA IS FREE OF DEFECTS IN MATERIAL OR WORKMANSHIP. IF, IN THE JUDGEMENT OF CUSHCRAFT, ANY SUCH ANTENNA IS DEFECTIVE, THEN CUSHCRAFT CORPORATION WILL, AT ITS OPTION, REPAIR OR REPLACE THE ANTENNA AT ITS EXPENSE WITHIN THIRTY DAYS OF THE DATE THE ANTENNA IS RETURNED (AT PURCHASER'S EXPENSE) TO CUSHCRAFT OR ONE OF ITS AUTHORIZED REPRESENTATIVES. THIS WARRANTY IS IN LIEU OF ALL OTHER EXPRESSED WARRANTIES, ANY IMPLIED WARRANTY IS LIMITED IN DURATION TO ONE YEAR, CUSHCRAFT CORPORATION SHALL NOT BE LIABLE FOR ANY INCIDENTAL OR CONSEQUENTIAL DAMAGES WHICH MAY RESULT FROM A DEFECT. SOME STATES DO NOT ALLOW LIMITATIONS ON HOW LONG AN IMPLIED WARRANTY LASTS OR EXCLUSIONS OR LIMITATIONS OF INCIDENTAL OR CONSEQUENTIAL DAMAGES, SO THE ABOVE LIMITATION AND EXCLUSION MAY NOT APPLY TO YOU. THIS WARRANTY GIVES YOU SPECIFIC LEGAL RIGHTS, AND YOU MAY ALSO HAVE OTHER RIGHTS WHICH VARY FROM STATE TO STATE. THIS WARRANTY DOES NOT EXTEND TO ANY PRODUCTS WHICH HAVE BEEN SUBJECT TO MISUSE, NEGLIGENCE, ACCIDENT OR IMPROPER INSTALLATION. ANY REPAIRS OR ALTERATIONS OUTSIDE OF THE CUSHCRAFT FACTORY WILL NULLIFY THIS WARRANTY.



THE ANTENNA COMPANY
 48 Perimeter Road, P.O. Box 4680
 Manchester, NH 03108

As part of our continuing research and development program we have improved the method by which we mount the X-Hat Assemblies on the loading coils of the 40-2CD 40 meter beams.

The drawing below replaces Figure 2B, which shows how to assemble and place the X-Hat Assemblies, and the parts list below the drawing indicates those parts required to make the necessary assembly changes.

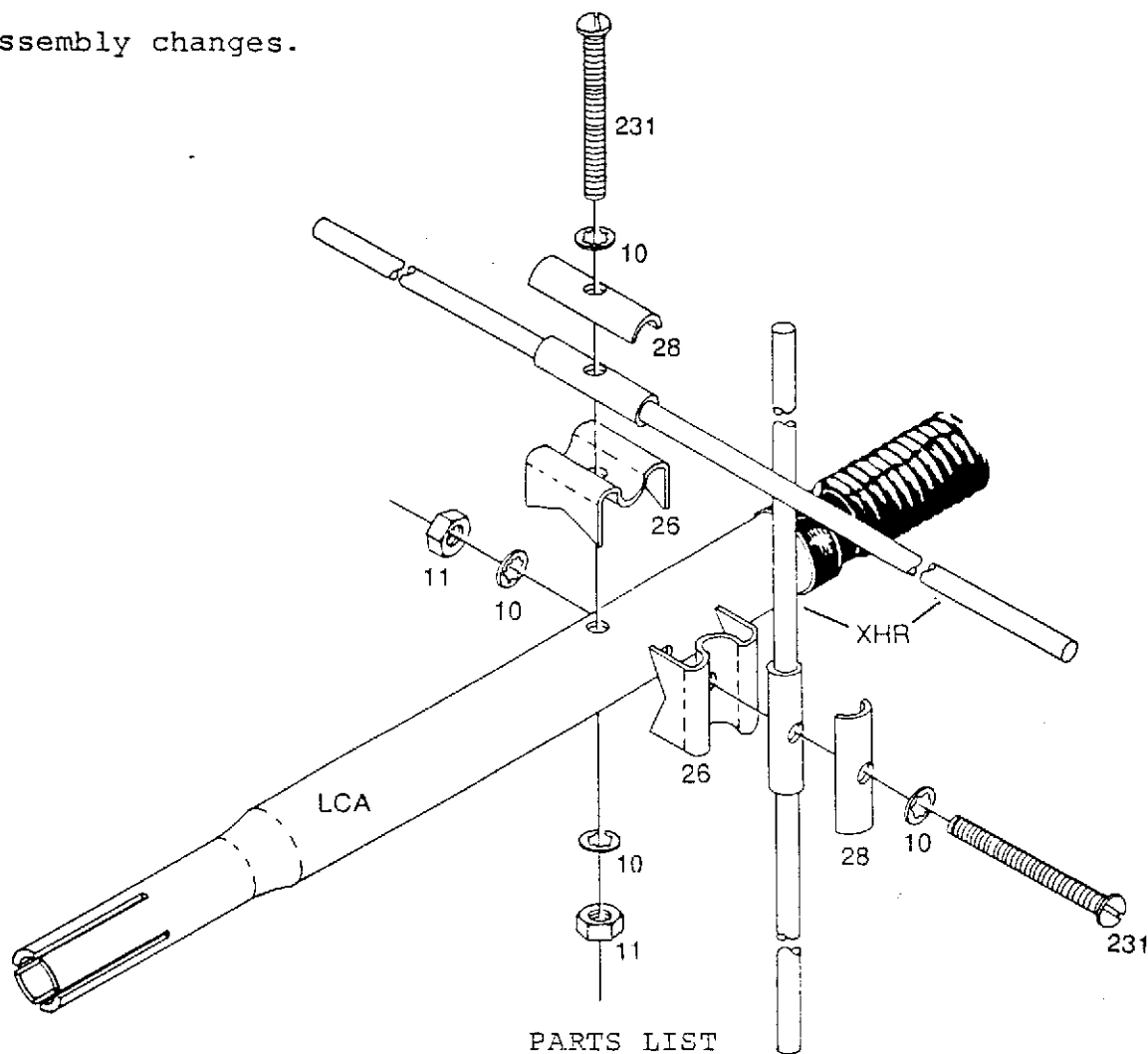

PARTS LIST

<u>P/N</u>	<u>KEY</u>	<u>DESCRIPTION</u>	<u>SIZE</u>	<u>QTY</u>
010231	231	Machine Screw	8-32x1 3/4" (4.4cm)	8 ✓
010010	10	Lock Washer	#8	16 ✓
010011	11	Hex Nut	8-32	8 ✓
190028	28	Aluminum Half Washer		8 ✓
190026	26	Formed Aluminum Bracket	7/8" (2.2cm)w/#8 Hole	8 ✓
LCA		Loading Coil Assembly	7/8"x23 1/2" (2.2x59.7cm)	4 ✓
XHR		Aluminum Rod	3/16"x34 1/2" (0.5x87.6cm)	8 ✓

BOOM ASSEMBLY CHANGES

In order to strengthen the boom of the 40-2CD, our research and development team have made some changes to the boom. The drawing below shows the changes in the boom as referred to Figure 1 in the manual. The change is as follows, the boom has been drilled and #232 screws and hardware have been added.

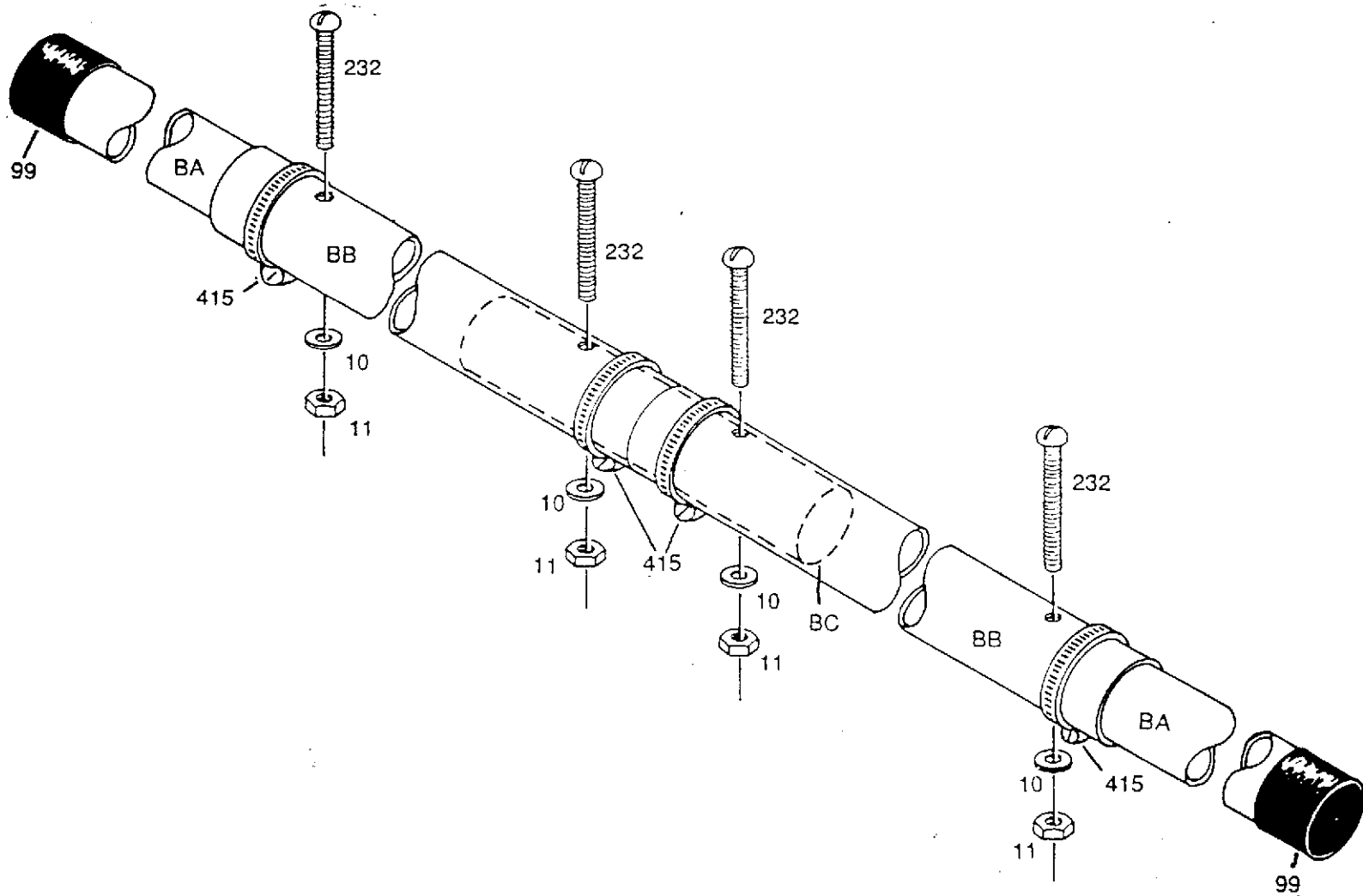

P/N	KEY	DESCRIPTION	SIZE	QTY
BA	BA	Aluminum Tubing	2"x56" (5.08x142.2cm)	2 ✓
BB	BB	Aluminum Tubing	2 1/8"x84" (5.4x213.36cm)	2 ✓
BC	BC	Aluminum Tubing	2"x18" (5.08x45.72cm)	1 ✓
030415	415	Worm Clamp	2 1/2 (6.35cm)	4 ✓
050099	99	Plastic Caps	2 (5.08cm)	2 ✓
010232	232	Machine Screws	8/32x2 1/2 (6.35cm)	4 ✓
010011	11	Hex Nuts	8/32	4 ✓
010010	10	Lock Washers	#8	4 ✓